

**SYSTEM INSTALLATION
AND INSPECTION MANUAL
HEATING OIL STORAGE TANK SYSTEMS**

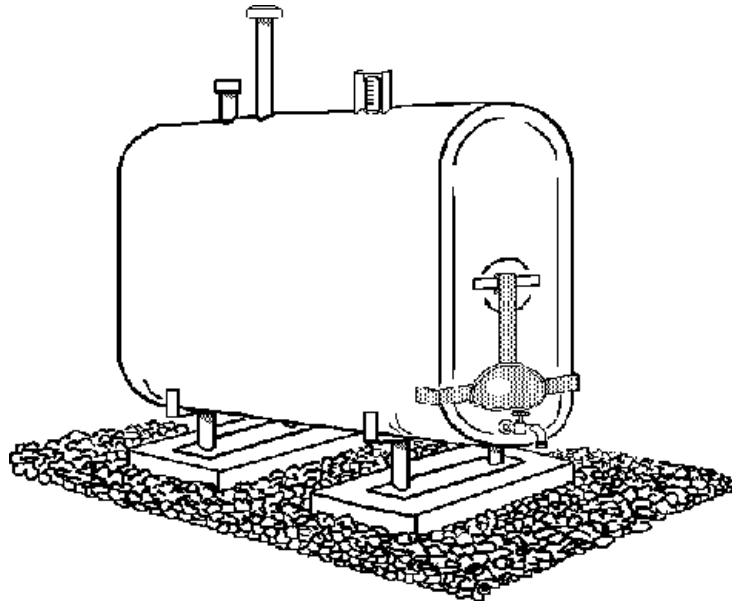

**GOVERNMENT OF NEWFOUNDLAND AND LABRADOR
DEPARTMENT OF ENVIRONMENT AND CONSERVATION**

**POLLUTION PREVENTION DIVISION
PETROLEUM STORAGE AND MANAGEMENT SECTION**

December 14, 2012

**SYSTEM INSTALLATION
AND INSPECTION MANUAL
HEATING OIL STORAGE TANK SYSTEMS**

TABLE OF CONTENTS	Page
INTRODUCTION	1-2
1) Requirements for Installation of Heating Oil Storage Tank Systems	3-5
1.1) Aboveground	3-5
1.2) Underground	5
2) Fill and Vent Piping for Heating Oil Storage Tank Systems	5-7
3) Product Lines for Heating Oil Storage Tank Systems	7-8
4) Registration of Heating Oil Storage Tank Systems	8
5) Registration Tags and Electronic Submissions	8-9
6) Storage Tank Relocation, Removal and Replacement	9-10
7) Updates & Contacts	10
FIGURES	11
Annex A – Tank Construction & Assigned Lifetime Information	12-14
- Tables of Assigned Lifetimes	13
Annex B – Vehicle Impact Protection	15
Annex C – Distance to Property Line	16
Annex D – New Lines	17-19
Annex E – Registration and Alteration	20-23
Annex F – Making an “Outside” Tank Registerable as an “Inside” Tank	24-25
Annex G – Tags Declared “Void”	26-27
Annex H – Storage Tank System Relocation	28-30
- Table of Remaining Useable Lifetimes for Relocated Tanks	29
- Sample Calculations for Relocated Tanks	30

INTRODUCTION

This manual has been prepared to clarify existing requirements and to define additional requirements. The implementation of the requirements of this manual, including those described in the Annexes, is being done to safeguard the quality of the environment in which all such heating oil storage tank systems must exist. This manual will provide guidance to a person installing or altering a heating oil storage tank system. Adherence to these, and other, requirements is a necessity to both protect the environment from preventable heating oil leaks and to obtain and maintain the registration of a system. Although anyone is permitted to conduct installation and alteration activities, including those described in this manual, it should be understood that a subsequent inspection of the work, by a licensed inspector, will be required. It is recommended that installation and alteration activities be conducted by Licensed Inspectors.

Licensed Inspectors please note!

- A system is not legally registered under the regulations until the registration information has been submitted electronically to government by the licensed inspector and that information must be complete, correct and demonstrate that the system meets all applicable requirements.
- It is recommended that clear and legible digital photos be taken of the heating oil storage tank system, including the HOST tag and the ULC label, after a system has been installed and/or inspected and registered and before leaving the property. Such photos can help verify information contained in the system checklist and may be helpful in confirming information at a later date as well.

Everyone please note!

- The requirements in this manual only apply to tanks with a capacity of 2500 litres or less and which are, or were, connected to a heating appliance for the purpose of space heating.
- Future editions or amendments of CSA-B139 shall come into force six months after the date they are published.
- The five year system reinspection requirement has been repealed and has been replaced by an inspection requirement at the call of the HOST administrator.
- CSA-B139, the "Installation code for oil-burning equipment", is a Canadian standard that was developed and is updated by a technical committee of volunteers representing various viewpoints and interests relating to the topics covered by the document. The first edition of that code came out over 50 years ago.
- All costs associated with inspections, repairs, upgrades or installations of heating oil

storage tank systems are set by the industry. Tank owners are strongly encouraged to discuss all potential costs with contractors or licensed inspectors and to obtain and check references before engaging such services.

- The Department does not respond to non-regulatory issues, such as workmanship, that may arise between a tank owner and contractors or licensed inspectors.
- Registered heating oil storage tanks can be sold to another person and be relocated to another property however the registration tag cannot be sold since it identifies the tank at the original property where it was installed, inspected and registered. When such a tank is bought and reinstalled elsewhere it is required to be inspected and registered at its new location.
- A registered single wall steel tank located outside cannot be moved to a new outside location either on the property where it was originally registered or to a new property as the new location would trigger the inspection and registration requirement and single wall steel tanks are no longer permitted, under code, to be installed outside.

1) **Requirements for Installation of Heating Oil Storage Tank Systems**

1.1) **Aboveground:**

1.1.1) A steel aboveground heating oil storage tank shall be installed:

- a) bearing a label in accordance with Section 6 of CAN/ULC-S602, "Standard for Aboveground Steel Tanks for Fuel Oil and Lubricating Oil" as amended; or
- b) bearing a label in accordance with Section 3 or 4, as applicable, of CAN/ULC-S601, "Standard for Shop Fabricated Steel Aboveground Tanks for Flammable and Combustible Liquids," as amended; or
- c) bearing a label indicating certification under such other standard or testing organization's evaluation regime as may be acceptable to the Administrator; and
- d) such that the label of the certifying agency is clearly visible.

See Annex A, "Tank Construction & Assigned Lifetime Information" for further information on assigned lifetimes.

1.1.2) The nominal steel sheet used in the fabrication of:

- a) single walled steel aboveground heating oil storage tanks shall be at least 2.3mm; and
- b) double bottom steel aboveground heating oil storage tanks shall be at least 2.0mm.

1.1.3) A non-metallic aboveground heating oil storage tank shall be installed:

- a) bearing a label in accordance with Section 5 of ULC/ORD-C80.1-2000 "Aboveground Non-Metallic Tanks for Fuel Oil," as amended; or
- b) bearing a label indicating certification under such other standard or testing organization's evaluation regime as may be acceptable to the Administrator; and
- c) such that the label of the certifying agency is clearly visible.

1.1.4) All aboveground heating oil storage tanks shall:

- a) be installed on a prepared bedding, designed to bear the gross weight of the tank filled with product;
- b) be installed on a solid base such as a concrete floor or a reinforced concrete pad when the installation is a new one. A reinforced concrete pad is recommended for the installation of replacement tanks. The reinforced concrete pad shall be suitably sized for the purpose, extending beyond the perimeter of the tank and shall be at least 150mm (6 in) thick;
- c) be supported by, when used, tank legs which are a minimum of schedule 40;
- d) not be installed directly, or indirectly (eg. concrete blocks on a wooden floor), on a wooden floor. Any tank installed in this manner cannot be registered;
- e) not be permitted to use tank legs which are higher than 300 mm (12 in) unless they are shown to meet the requirements, for rigid non-combustible supports, of CSA-B139;
- f) use tank leg support brackets where the tank legs are more than 200 mm (8 in) high, however their use is recommended in all situations;
- g) where concrete blocks are used, be supported on blocks which are at least 600 mm × 300 mm × 50 mm (24 in × 12 in × 2 in) and be reinforced such that the blocks

may crack but not break apart. A cracked reinforced concrete block shall be replaced as soon as possible. Cracked reinforced concrete blocks shall not be permitted to remain in place under new, replacement or relocated tanks. (See Fig. 1)

- h) not block doorways or windows, including basement windows;
 - i) be located such that there is a minimum clearance of 460 mm (18 in) from one side and the product supply valve end of the tank and a minimum of 50 mm (2 in) from the remaining side and end of the tank to any nearby structure or wall to allow access for inspection of the tank including the tank's bottom;
 - j) have the product lines protected from damage by running them along the edge of the wall and/or by placing a suitable impact resistant cover over them;
 - k) for an end outlet tank, be provided with protection for the product supply valve by using a tank outlet protector (see 1.1.7);
 - l) be protected from vehicular damage if not located in an area separated from vehicular movement or not otherwise protected by its location (See Annex B, "Vehicle Impact Protection" for further information); and
 - m) be installed and maintained so that the certification label (e.g. ULC label) remains visible and legible.
- 1.1.5) An outside aboveground heating oil storage tank system:
- a) shall, for a product line from an end outlet tank, incorporate provisions for expansion, contraction, jarring, vibration, settling, frost heaving and other movement of the product line. Suitable arrangements include, but are not limited to, the use of a horizontal loop or an 'S' shape in the product line between the tank and the wall or ground;
 - b) should be located at least 1.5 m (5 ft) from a property line (see Annex C, "Distance to Property Line");
 - c) should not be located directly under the eave of a house where it may be subject to falling icicles or snow or increased external pitting from dripping water; and
 - d) should be located a minimum of 30 m (100 ft) from a well. Where this is not practical, an inside aboveground heating oil storage tank system and/or secondarily contained system should be considered.
- 1.1.6) An inside aboveground heating oil storage tank system shall:
- a) not exceed 230 L (50 gal) capacity where the tank is located above the lowest storey, cellar or basement unless it is installed in a manner compliant with CSA-B 139;
 - b) be located at least 600 mm (2 ft) from any fuel-fired appliance, unless it is completely shielded from the appliance by a wall of non-combustible construction; and
 - c) be located at least 1m from any electrical panel.
- 1.1.7) A tank outlet protector:
- a) shall be of durable construction;
 - b) shall attach/fasten to the tank with, if necessary, materials meeting (a);
 - c) shall be readily removable to allow easy access for valve maintenance or repair;
 - d) shall, as viewed from above, completely cover an end outlet valve;

- e) should be of non-combustible material; and
- f) should not provide a step or surface to stand on.

1.2) Underground:

- 1.2.1) A steel underground heating oil storage tank shall be installed bearing a label in accordance with Section 4 of CAN/ULC-S603, "Standard for Steel Underground Tanks for Flammable and Combustible Liquids" and shall be corrosion protected in accordance with CAN/ULC-S603.1 "Standard for External Corrosion Protection Systems for Steel Underground Tanks for Flammable and Combustible Liquids" as amended.
- 1.2.2) A fibreglass underground heating oil storage tank shall be installed bearing a label in accordance with Section 6 of ULC-S615, "Standard for Reinforced Plastic Underground Tanks for Flammable and Combustible Liquids" as amended.
- 1.2.3) Only double walled, or otherwise secondarily contained, underground tanks shall be installed. The interstice of such tank installations shall be constantly monitored for the presence of hydrocarbons or water which may indicate a leak. The monitoring device shall be installed in such a manner that it visually or audibly alerts the tank owner of the presence of a leak.
- 1.2.4) Underground product lines shall be installed in accordance with the requirements of the "Underground piping or tubing" section of CSA-B139.
- 1.2.5) Underground product lines shall also include a containment sump located at the lowest point in the run to help in the detection and removal of leaking heating oil. The sump must be accessible from ground level. This can also be accomplished by means of a containment sump located inside the building if the sump would be lower than the underground piping or tubing outside.
- 1.2.6) An underground heating oil storage tank system shall be at least:
 - a) 1.5 m (5 ft) from a property line; and
 - b) 1 m (39 in) from a building.

2) Fill and Vent Piping for Heating Oil Storage Tank Systems

- 2.1) The fill and vent pipe material shall be:
 - a) new;
 - b) either of steel or galvanized construction; and
 - c) a minimum of schedule 40.See Annex D, "New Lines" for additional requirements on fill and vent pipe replacement.
- 2.2) The nominal inside diameter of a fill pipe shall not be less than 50 mm (2 in).
- 2.3) The height of a fill pipe of an outdoor tank shall not be less than 50 mm (2 in).

- 2.4) The inlet to the fill pipe shall, in the case of an indoor tank, be located at an elevation of at least 1 m (39 in) above the outside ground level.
- 2.5) The inlet to the fill pipe of a tank shall be at least 300 mm (12 in) above the elbow, in the event that an elbow is used in the fill pipe.
- 2.6) The inlet to the fill pipe shall be located outside buildings, not be less than 600 mm (2 ft) from any building opening such as a doorway, window or intake duct and be provided with a tight metal cover.
- 2.7) Cross-connected steel or fiberglass tanks provided with a single fill pipe, shall have the fill pipe connected to the first tank (see Figure 2).
- 2.8) The size of a cross-over pipe shall not be less than the size of the fill pipe (see Figure 2).
- 2.9) Threaded joints in fill and vent piping shall be made fuel oil-tight using joint compound or tape conforming to CAN/ULC-S642-M, "Standard for Compounds and Tapes for Threaded Pipe Joints" or such other joint compounds which are recognized as suitable for the purpose of use in petroleum service.
- 2.10) Vent pipes shall not be less than:
 - a) 32 mm (1¼ in) nominal inside diameter; or
 - b) 50 mm (2 in) nominal inside diameter where two or more tanks share a cross-connected vent pipe.
- 2.11) Where cross-connected steel or fiberglass tanks have combined venting a cross-connected vent pipe shall be connected to the tops of both tanks and a vent alarm shall be installed only in the tank which has the fill pipe (see Fig. 2).
- 2.12) The vent pipe shall:
 - a) be installed to drain toward the tank;
 - b) not extend into the tank more than 25 mm (1 in); and
 - c) be connected to a vent alarm.
- 2.13) The vent pipe shall be sized in accordance with the length used and the number and type of elbows necessary for its construction. Specific guidance on this topic can be found in Section 7.9 and Annex 'F' of CSA-B139-09.
- 2.14) The vent pipe outlet shall, in the case of an indoor tank, terminate to open air outside at an elevation of at least 1.15 m (45 in).
- 2.15) The vent pipe outlet of any tank shall:
 - a) terminate at an elevation which is at least 150 mm (6 in) above the inlet to the fill pipe;
 - b) not be less than 600 mm (2 ft) from any opening such as a doorway, window or intake duct; and

- c) be provided with a weatherproof vent cap.
- 2.16) Joints in vent and fill pipes should be kept to a minimum.
- 3) Product Lines for Heating Oil Storage Tank Systems**
- 3.1) The product line material shall be:
- a) new;
 - b) either of wrought iron, steel, or brass pipe: or brass, copper, or steel tubing; and
 - c) if copper tubing, a minimum of type 'L'.
- See Annex D, "New Lines" for additional requirements on product line replacement.
- 3.2) Nipples used to attach the product delivery or shut-off valve to a tank shall be a minimum of schedule 40 black iron and shall be a maximum of 75 mm (3 in) in length.
- 3.3) Valves used to control the delivery of product from a tank shall be of brass or stainless steel construction with a minimum rating of 850 kPa (125 PSI) and shall be either a gate or ball type, certified for use with oil, and be located as close as practicable to the tank shell. Information as to the rating and certification of the valve shall either be on the valve or the valve shall be otherwise suitably identified such that its rating and certification can be verified.
- 3.4) All product lines are to include a fusible link valve installed in accordance with the manufacturer's instructions.
- 3.5) Threaded joints in the product lines shall be made fuel oil-tight using joint compound or tape conforming to CAN/ULC-S642-M, "Compounds and Tapes for Threaded Pipe Joints" or such other joint compounds which are recognized as suitable for the purpose of use in petroleum service.
- 3.6) All connections in copper product lines shall be made fuel oil-tight using a flared joint. Compression fittings are not permitted.
- 3.7) A product filter assembly, where used, shall:
- a) be installed inside a building;
 - b) have sufficient clearance to allow for maintenance, replacement or repair; and
 - c) be replaced with a new unit, when a new or replacement tank is being installed, unless the filter assembly is 12 months old or less.
- 3.8) Copper product lines shall not be in direct contact with concrete as the chemicals in the concrete cause accelerated corrosion of the copper product line. The copper product line shall be isolated by intentionally choosing a route from the tank to the furnace which avoids concrete, by placing a material between the copper product line and the concrete or by using a coated copper product line.
- 3.9) Installing a product line directly in concrete is not acceptable. If unavoidable, the product

line shall be placed in a continuous run of flexible non-corrodible petroleum resistant tubing when installed in a concrete floor. The flexible non-corrodible petroleum resistant tubing must protrude at least 50 mm (2 in) above the concrete floor at both ends.

- 3.10) A product line which is buried underground shall be installed in accordance with clause 1.2.4 of this manual.
- 3.11) Product lines shall not be less than 10 mm (3/8 in) outside diameter. If located outside, 13 mm (1/2 in) minimum outside diameter is recommended to reduce the potential for freezing.
- 3.12) Joints in product lines should be kept to a minimum.

4) Registration of Heating Oil Storage Tank Systems

- 4.1) The registration of a heating oil storage tank system requires that an inspection, by a licensed inspector, be conducted. Any deficiencies found shall be corrected prior to the storage tank system being registered.
- 4.2) Some tank owners will install their own tanks or have another person install their tanks for them. Any person planning to do this should first make contact with a licensed inspector to check that the inspector will inspect and register a tank that the inspector has not installed himself. Some inspectors will inspect and register a tank that someone else has installed but they are not required to by the regulation. That is their choice.
- 4.3) The requirements, and the timing, for when a storage tank system shall be registered depends on whether the system is considered a new, existing, altered or temporary system. Annex E, "Registration and Alteration" discusses in detail the registration of each such system.
- 4.4) An "outside" tank can be registered as an "inside" tank if the system has been suitably contained and protected so that it can be considered equivalent to an "inside" tank installation. See Annex F, "Making an "Outside" Tank Registerable as an "Inside" Tank".

5) Registration Tags and Electronic Submissions

- 5.1) Numbered brass tags are sold by the Department to Licensed Inspectors for the purpose of providing a visual indicator that a system has been registered. Once a Licensed Inspector has determined that a system is registerable, a brass tag, identifying the system, will be fastened to the system's vent pipe using two rivets. The Licensed Inspector will also identify the useable lifetime of the particular system by placing four digits on the tag which will show the month and year by which the system must be replaced. These four digits shall be **punched** into the metal of the tag using numeric punches.

For the purpose of registering an existing system the actual date of installation shall be

used. If the actual installation date is unknown or cannot be shown to the satisfaction of the Licensed Inspector then either:

- (a) an assumed installation month of June and the year that the tank was manufactured (as determined from the certifying agency label - such as ULC, Warnock Hersey, etc.) shall be used; or
- (b) if the month and year of manufacture is shown on the certifying agency label then that information shall be used as the assumed installation date.

If the installation date is unknown and there is no certifying agency label then the system cannot be registered.

- 5.2) Once the system has been “tagged” as registered, the Licensed Inspector shall provide the tank owner with the tank system’s Certificate of Registration before leaving. If this is not possible then a completed Certificate of Registration for the tank system shall be delivered to the tank owner within seven (7) days of the inspection.
- 5.3) The information recorded by the Licensed Inspector during the inspection of each tank system is recorded on a checklist issued by the Department. In accordance with the regulations, this information shall be transferred into an electronic spreadsheet and submitted to the Administrator on a regular basis. Licensed Inspectors are required to submit electronic registration information records by the end of the month following the month in which a system was inspected and registered by them. If no registration activities were conducted during the previous month then such inactivity must be reported by the end of the following month. If electronic submissions do not occur on a regular, or as requested, basis then further purchases of HOST tags will be delayed and the processing of license renewals may be delayed. Continual, or extended, problems in this area may result in the Licensed Inspector having their License suspended or revoked.
- 5.4) A HOST tag may be declared “void” by a Licensed Inspector or by the Administrator. If a tag has been declared “void” then any tank to which it is attached would be considered unregistered. Such a tank must be removed from service if its useable lifetime has expired or must be inspected and registered if there is useable lifetime remaining for it. The usual circumstance under which a HOST tag would be declared “void” is that no registration information concerning a system to which the tag is or was supposed to be attached has ever been submitted to the Department. A declaration of “void” is permanent. Further details may be found in Annex G, “Tags Declared Void”.

6) Storage Tank Relocation, Removal and Replacement:

- 6.1) When a storage tank system is being relocated from an inside to an outside location or from an outside to an inside location the duration of its life will need to be adjusted. Annex H, “Storage Tank System Relocation” provides an explanation of this adjustment. In such situations, this would require the fastening of a new tag and the submission of electronic registration if this is an already registered tank.

- 6.2) When a storage tank is being removed from service, fuel may be pumped out and placed in another fuel storage tank for later use. The fuel shall be pumped out to a level no lower than 200mm (8 in) from the bottom of the tank. This should be done carefully to ensure that no contaminants from the sludge at the bottom of the tank are drawn into the suction line. The fuel then remaining in the tank shall be pumped off for appropriate disposal. Next, the residual sludge in the bottom of the tank shall be thoroughly removed for appropriate disposal. Finally, the tank itself shall be sent for appropriate disposal (usually recycling). Ideally, when a tank is being replaced on a scheduled basis, the fuel in the tank should be fully consumed so that there is no need for any fuel transfer.

7) **Updates & Contacts:**

- 7.1) This **fourth** edition of the manual was published on December 14, 2012 and replaces the third edition dated November 26, 2010. Given the nature of the information in the document and the fact that it may be appropriate, from time to time, to provide additional information or guidance on practical, technical or regulatory issues, any person using this document should check to see that they are referring to the latest version. This manual is available for viewing, or download, on the Department of Environment and Conservation's website - www.env.gov.nl.ca/env/publications/env_protection/siim.pdf

For this information or for any other questions you may have concerning the Heating Oil Storage Tank System Regulations, 2003 you can call the toll-free number, 1-800-563-6181 or locally call 729-0948 or 729-2556.

Please note that this manual now incorporates some of the changes included in the 2009 version of the CSA-B 139 Installation Code for Oil-Burning Equipment. That version of the Code is to be followed for all heating oil storage tank system installations, alterations and registration inspections. Reference to your own copy of the 2009 edition should be made in order to determine and understand all the changes made to that code.

Figure 1. Aboveground Installation

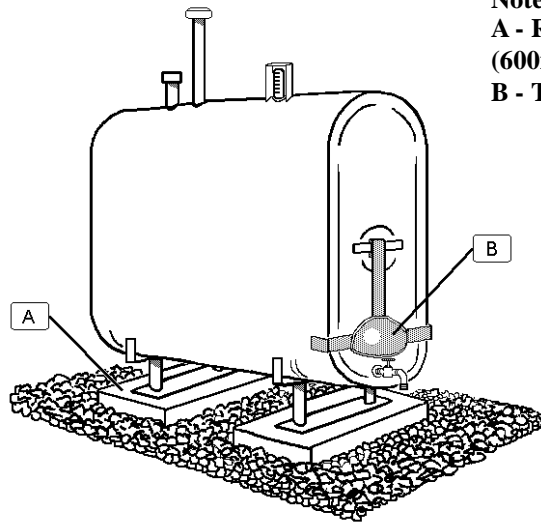

Notes:
A - Reinforced Concrete Block
(600mm × 300mm × 50mm)
B - Tank Outlet Protector

Figure 2: Cross-Connected Tanks

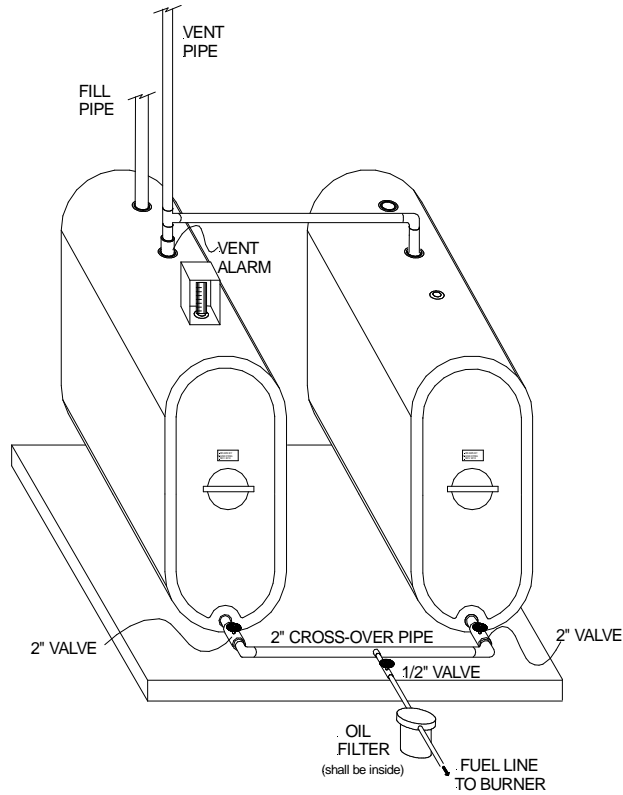

ANNEX A
TANK CONSTRUCTION & ASSIGNED
LIFETIME INFORMATION

First, 14 gauge single wall steel tanks can no longer be constructed under the 2007 edition of the ULC-S602 standard. Existing tanks that are already installed may remain in use for their assigned lifetime but there should be very few new installations of 14 gauge tanks since they can no longer be constructed and certified to the CAN/ULC-S602-07 standard.

The minimum permissible thickness of metal allowed to be used in the construction of a single wall S602 tank is now 2.10 mm. That equates to a minimum nominal thickness of 2.30 mm.

The assigned values for lifetime previously associated with 12 gauge will now be assigned to these tanks. For example, a bottom outlet tank located inside, constructed of steel with a minimum permissible thickness of 2.10 mm will be assigned a useable lifetime of 25 years.

There is now also a new version of the S602 tank that is covered by the 2007 edition and it is a double bottom tank. There are two versions of this design. The first one provides for a double bottom which just covers the bottom shell of the tank. The second one provides for a double bottom which covers both the bottom shell and the lower portion of both heads of the tank.

Double bottom tanks can be constructed of thinner steel. Their minimum permissible thickness is 1.80 mm. That equates to a minimum nominal thickness of 2.0 mm which essentially is the same as 14 gauge.

Double bottom tanks are assigned additional lifetime. The first version, the one which provides a double bottom for the shell only, would be assigned an additional lifetime of 5 years. The second version, the one which provides a double bottom for both the shell and the lower portion of both heads, would be assigned an additional lifetime of 10 years. For example, a bottom outlet 14 gauge tank located outside which is a double bottom shell only type would be assigned a useable lifetime of 20 years. If the double bottom tank included protection of the lower portions of both heads then it would be assigned a useable lifetime of 25 years. Each version of this tank would be assigned an additional five years if the tank were located inside. Each version of this tank would also be assigned an additional five years if the tank were constructed using thicker steel.

TABLES OF ASSIGNED LIFETIMES

The following tables provide a more complete picture of assigned lifetimes.

Gauge (minimum permissible steel thickness)	Assigned Lifetime (in years)			
	Steel Single Wall Tank			
	End or Top Outlet		Bottom Outlet	
	Outside*	Inside	Outside*	Inside
14 (1.80 mm)	10	15	15	20
13 (2.10 mm)	15	20	20	25
12 (2.30 mm)	15	20	20	25

Gauge (minimum permissible steel thickness)	Assigned Lifetime (in years)			
	Steel Double Bottom (Shell Only) Tank			
	End or Top Outlet		Bottom Outlet	
	Outside	Inside	Outside	Inside
14 (1.80 mm)	15	20	20	25
13 (2.10 mm)	20	25	25	30
12 (2.30 mm)	20	25	25	30

Gauge (minimum permissible steel thickness)	Assigned Lifetime (in years)			
	Steel Double Bottom (Shell & Lower Heads) Tank			
	End or Top Outlet		Bottom Outlet	
	Outside	Inside	Outside	Inside
14 (1.80 mm)	20	25	25	30
13 (2.10 mm)	25	30	30	35
12 (2.30 mm)	25	30	30	35

* A single wall steel tank can no longer be installed outside.

The following tank arrangements would be assigned useable lifetimes of 50 years:

- An aboveground tank with secondary containment, monitored interstice and either outside with secondary containment that keeps out rain and snow or inside with secondary containment where the structure or building keeps out rain and snow.
- A ROTH tank which is a high density polyethylene tank inside a galvanized steel secondary containment and monitored interstice.
- A single walled or double walled aboveground fiberglass tank located inside or outside.
- An underground tank with secondary containment of the tank and associated underground lines with all interstices monitored.

Some stainless steel tanks were installed and registered and these were built to ULC-S602 standards. Such tanks were assigned the same lifetime as for the equivalent mild steel version (See HOST Section 15 or Tables of Assigned Lifetimes)

There was also a Concepts Atlantic Corporation (CAC) tank sometimes referred to as a CAC SAFE Tank. This tank was a 6mm thick HDPE tank inside a 14 gauge steel tank and was only available with a top outlet. This tank was installed and was eligible for registration up until September 30, 2006. After that date a CAC SAFE tank could not be registered. Such tanks that had been registered before that date were assigned a useable lifetime of 40 years and they can be used at their registered location until the registration expires. It should be noted that such tanks cannot be moved to another location as they can no longer be registered at a new site.

For a tank which has not been described above, reference shall be made to the Administrator who shall consider the characteristics of the tank and who may assign a useable lifetime, to the tank, which shall not exceed 50 years.

Please note that "maximum periods" as mentioned in Section 15 of the HOST regulations or "useable lifetimes" as mentioned in this Manual are not to be considered as guarantees that any given tank will provide safe continuous service for the specified period. It is possible that a tank may cease to provide safe continuous service well before the period specified in the regulations or the Manual.

Tank owners are responsible for the operation of their tank and should regularly monitor the condition of their tanks. If a tank owner, heating oil supplier or heating services contractor determines that a tank is in a deteriorated condition before the "maximum period" or "useable lifetime" has been reached then such a tank must be taken out of service and replaced with a new system to ensure the protection of the environment.

ANNEX B

VEHICLE IMPACT PROTECTION

When a tank is not located in an area separated from vehicular movement or is not otherwise protected by its location, the tank, its equipment, and the piping attached to it shall normally be protected from damage with either posts or guardrails, as specified below.

Situations where a tank would require such vehicle impact protection measures would include, but not be limited to, the following:

- a) The tank is located outside next to or at the end of a driveway or in a carport.
- b) The tank is located in a residential or commercial garage that is or can be used for the parking, storage or maintenance of a vehicle or vehicles.
- c) The tank is located outside in, next or adjacent to a parking lot.
- d) The tank is located inside a commercial or institutional parking garage.

A vehicle driven in such areas could easily come into contact with the tank by accident, inattention or slippery conditions.

Posts used for the protection of a tank shall

- a) be spaced not more than 1350 mm (53 in) apart;
- b) be buried not less than 915 mm (36 in) below grade;
- c) extend at least 760 mm (30 in) above grade level; and
- d) be one of the following:
 - (i) 100 mm (4 in) capped steel pipe;
 - (ii) 100 mm (4 in) tubing filled with concrete;
 - (iii) 200 mm (8 in) pressure-treated wood, either square or round; or
 - (iv) 150 mm (6 in) minimum dimension reinforced concrete.

Guardrails used for the protection of a tank shall be either

- a) of the steel deep-beam type 305 x 4050 mm (12 x 160 in) supported by 150 mm (6 in) minimum pressure-treated wooden posts located not more than 1880 mm (74 in) apart, centre to centre, and with the top of the beam not more than 610 mm (24 in) above grade; or
- b) of the reinforced concrete barrier type, commonly referred to as the New Jersey Turnpike barrier, not less than 760 mm (30 in) in height and with the width of the base not less than the height.

Posts or guardrails used for the protection of a tank shall be located not less than 1 m (39 in) from all sides of the tank.

Other arrangements, if deemed suitable by the inspector, may also be acceptable.

ANNEX C

DISTANCE TO PROPERTY LINE

Both CSA-B139 and this manual discuss the issue of distance to the property line. This manual states that a minimum distance of 1.5 m (5 ft) should be maintained. CSA-B139 states that a minimum distance of 1.5 m (5 ft) shall be maintained unless otherwise permitted by the regulatory authority.

Existing Storage Tank System Being Registered

With respect to an existing storage tank system being registered, the Department will accept the registration of such a storage tank system if all other requirements except this one are met. If there is another location on the property which would be suitable for a storage tank system to be located and which would meet all requirements including this one then, at the time the existing storage tank system is replaced, the replacement storage tank system shall be installed at the fully compliant location.

Existing Storage Tank System Being Replaced

Up to May 31, 2013, with respect to an existing storage tank system being replaced, the Department will accept the registration of such a storage tank system if all other requirements except this one are met but only under the following two conditions:

- a) there is no other location on the property which would be suitable for a storage tank system to be located and which would meet all requirements including this one; and
- b) the municipality in which the property is located provides a written authorization for the location of the storage tank system, either specifically for each such storage tank system or generally for such storage tank systems in its jurisdiction.

As of June 01, 2013 the Department will accept the registration of such a storage tank system if all other requirements except this one are met but only under the following two conditions:

- a) there is no other location on the property which would be suitable for a storage tank system to be located and which would meet all requirements including this one, and
- b) the municipality in which the property is located has not provided a written prohibition for the location of the storage tank system, either specifically for each such storage tank system or generally for such storage tank systems in its jurisdiction.

In all cases, if there is another location on the property which would meet all requirements including this one then the replacement storage tank system shall be installed at the fully compliant location.

ANNEX D **NEW LINES**

For a brand new installation:

Where a new (first time) heating oil storage tank system is being installed, such as at a new home or a heating source conversion (electric to oil heat), everything shall be new. This includes fill, vent and product lines. No old, recycled or used lines shall be used in such installations.

For an existing system being registered:

If the existing lines meet the requirements, then no new lines will be necessary.

If copper or some other unacceptable material is being used as vent or fill piping then that shall be replaced with appropriate new materials.

Where a vent or fill pipe is being changed to a required diameter the entire vent or fill pipe shall be replaced with new materials.

Where a vent or fill pipe is being extended to meet “height” or “distance to openings” requirements the fittings and piping being added shall be new materials.

Where a vent or fill pipe is in a deteriorated condition the entire vent or fill pipe shall be replaced with new materials.

Where product lines require replacement then the replacement product line shall be new material.

If an unacceptable material is being used as a product line then that shall be replaced with appropriate new materials.

For an existing system being replaced:

If the existing product line is of an unknown age or is an age that is equal to or greater than the useable lifetime which would be assigned to the attached existing tank then such a product line shall be replaced with new materials.

If the existing product line is less than 10 years old, and is in good condition, then that product line may be reused if it meets then current requirements.

If the existing product line is more than 10 years old it must be replaced.

If the existing vent or fill pipe is in a deteriorated condition the entire vent or fill pipe shall be replaced with new materials.

If existing vent, fill or product lines will be reused, every accessible threaded joint shall be separated, the male and female threads cleaned and the joint shall then be remade using tape or compound conforming to ULC-S642 or such other joint compounds which are recognized as suitable for the purpose of use in petroleum service.

If existing vent, fill or product lines will be reused, threaded joints behind walls, in ceilings or otherwise hidden shall be accessed.

Any inaccessible joint in vent, fill or product lines shall have its integrity verified by the use of a hydraulic pressure test. A pressure of 350 kPa or 1.5 times the operating pressure of the line, whichever is greater, shall be applied to the applicable line and the pressure shall be held for a minimum of 2 hours. Any drop in pressure or volume loss after steady temperature conditions have been established and the source of pressure has been removed will indicate a leak and the vent, fill or product line shall be replaced with new materials. Precautions shall be taken to ensure that the tank is not subjected to such a pressure.

For a registered system being replaced:

If the registered system has reached, or is within 12 months of, its assigned useable lifetime then the tank and all product lines shall be replaced.

If the registered system's tank has leaked and is being replaced, the product line, if installed with the registered tank, or since the tank was registered, and if less than 10 years old and in good condition, may be reused if it meets then current requirements.

A product line that is of unknown age or is more than 10 years old shall be replaced with new materials.

If the existing vent or fill pipe is in a deteriorated condition the entire vent or fill pipe shall be replaced with new materials.

If existing vent, fill or product lines will be reused, every accessible threaded joint shall be separated, the male and female threads cleaned and the joint shall then be remade using tape or compound conforming to ULC-S642 or such other joint compounds which are recognized as suitable for the purpose of use in petroleum service.

If existing vent, fill or product lines will be reused, threaded joints behind walls, in ceilings or otherwise hidden shall be accessed.

Any inaccessible joint in vent, fill or product lines shall have its integrity verified by the use of a hydrostatic pressure test. A pressure of 350 kPa or 1.5 times the operating pressure of the line, whichever is greater, shall be applied to the applicable line and the pressure shall be held for a minimum of 2 hours. Any drop in pressure or volume loss after steady temperature conditions have been established and the source of pressure has been removed will indicate a leak and the vent, fill or product line shall be replaced with new materials. Precautions shall be taken to ensure that the tank is not subjected to such a pressure.

For all situations:

Under all circumstances discussed in this document it should be noted that:

- a) the nipple used to connect the required shutoff valve to a tank is considered to be part of the product line. Accordingly, this nipple shall be replaced, or may be reused, in accordance with the requirements placed upon product lines in the particular circumstance.
- b) unions, elbows and other such fittings used in the construction of fill, vent and product lines shall also be replaced, or may be reused, in accordance with the requirements placed upon the vent, fill or product lines in the particular circumstance.
- c) the condition of fill, vent and product lines can be adversely affected by their location, installation, maintenance and other external considerations. The low age of such lines is no excuse for not replacing such lines when they are in poor condition. This is an issue left to the judgement of a Licensed Inspector. It would also be the responsibility and, perhaps, liability of the Licensed Inspector should the choice be made to leave a line which is in an obvious poor condition if a leak or spill were to occur from such a line.

ANNEX E

REGISTRATION AND ALTERATION

1. Sections 5 and 6 of the regulations require that new, altered and existing systems must be registered. Registration may mean different things depending upon the situation such as:
 - a) For a new or replacement system, registration can occur once the system has been inspected by a licensed inspector and found to comply with the regulations and the requirements of CSA-B139, the tank manufacturer's instructions and this manual. Any deficiencies found as a result of this inspection will have to be corrected before the registration can be completed. Deficiencies, for the purpose of registration, are technical issues which vary from the requirements of the regulations, CSA-B139, tank manufacturer's instructions and this manual.
 - b) For an existing system that is being registered, registration can occur once the system has been inspected by a licensed inspector and found to comply with the regulations and the requirements of CSA-B139, the tank manufacturer's instructions and this manual. Any deficiencies found as a result of this inspection will usually have to be corrected before the registration can be completed.
 - c) For a system that has already been registered and which has subsequently been altered, an actual registration will not occur (except for tank relocations) however the system will have to be inspected by a licensed inspector to determine whether the system still complies with the regulations and still meets the requirements of the edition of CSA-B139 which was applicable when it was originally inspected and registered. That part of the system that was altered will have to be inspected to make sure it meets the requirements of the current edition of CSA-B139, the tank manufacturer's instructions and this manual. Any deficiencies found as a result of this inspection will have to be corrected for the system to maintain its registration.
 - d) For an existing system that has not yet been registered, if such a system is altered then it will have to be registered. Registration can occur once the system has been inspected by a licensed inspector and found to comply with the regulations and the requirements of CSA-B139, the tank manufacturer's instructions and this manual. Any deficiencies found as a result of this inspection will usually have to be corrected before the registration can be completed.

There are some issues which can be looked at differently for existing tanks and these items may remain uncorrected if their correction is not feasible. Such items include the requirements of 1.1.4(i), 1.2.6 and 3.2 of this manual.

2. To clarify the issue of timing, with respect to the four situations described in 1, one should note that:
 - a) For the situation described in 1(a) although no time frame is specified within which

the registration must occur, the registration of the system must normally be completed before any heating oil can be put into the heating oil storage tank system.

A temporary system may be installed, filled and used without being registered but the installation and use of a temporary system shall meet all other requirements of the regulations, this manual, the applicable CSA-B139 code and the applicable manufacturer's installation instructions. A temporary system may be used for a period of not more than 60 days after it has been first filled. After the expiration of the 60 day period, the temporary system shall be registered or the system shall be immediately disconnected, emptied, dismantled and removed from the property. A temporary system shall only be installed and used on a property once in a twelve month period. Where, in the opinion of the administrator, the installation and use of a temporary system does not conform to all other requirements, the administrator may require that the owner of the temporary system immediately cease to use it and disconnect, empty, dismantle and remove the temporary system from the property.

- b) For the situation described in 1(b) the registration of most systems should have already been completed. If any deficiencies are present which have to be addressed and the correction of such deficiencies involves an alteration of the system, as described in 4(a), then all deficiencies must be corrected and the system must be registered at that time.

It should be noted that an existing system that has a storage tank whose age is already at or beyond the age limit stated in Section 15 will not be registered. Such a storage tank should be removed and/or replaced immediately.

- c) For the situation described in 1(c) that part of the system that has been altered must be inspected by a licensed inspector within 30 days of the alteration having taken place. If any deficiencies are present their correction shall be completed and the system reinspected by a licensed inspector within 30 days of the inspector's first deficiency report being presented to the system owner. If deficiencies are still found during this second inspection the system's registration shall be temporarily revoked, the registration tag shall be removed and the system shall be emptied and not refilled until such time as the system has been inspected and found to comply with all requirements as described in 1(c), and has its registration reinstated and its registration tag reapplied to the vent.
- d) For the situation described in 1(d) the registration of most systems should have already been completed. It must be registered before any further heating oil can again be put into the heating oil storage tank system. The entire system must be inspected by a licensed inspector within 30 days of the alteration having taken place. If any deficiencies are present their correction shall be completed and the system reinspected by a licensed inspector within 30 days of the inspector's first deficiency report being presented to the system owner. If deficiencies are still found during this second inspection the system shall be emptied and shall not be refilled until such time as the system has been inspected and found to comply with the regulations and the

requirements of the current edition of CSA-B139, the tank manufacturer's instructions and this manual, and has been registered. Again, the registration of the system must normally be completed before it can be refilled.

It should be noted that an existing system that has a storage tank whose age is already at or beyond the age limit stated in Section 15 will not be registered. In such a situation, the storage tank shall be replaced.

3. For the purpose of dealing with potential problems which arise in 2(a), (c) and (d) and in accordance with Subsection 17(2) of the regulations, the administrator may vary the time period to meet the registration requirement. Such a variance could allow the system to be filled prior to it being registered which would still be required within a period of time specified by the administrator.
4. Since the word "alter" has a very inclusive definition it would be helpful to tank owners and inspectors to note a number of activities which, for the purpose of the regulation, would or would not be considered as "alterations". An "alteration" is usually, although not always, characterized by the fact that the activity can be conducted at a scheduled, normal work day, time. Activities which are not considered "alterations" are usually, although not always, characterized by the fact that the activity is more often of an "emergency", nights and weekends, nature requiring immediate fixing. The activities contained in the following lists are provided as examples. They do not exclude other activities which may or may not be considered "alterations". The Administrator should be contacted to determine if other specific activities would be considered "alterations".
 - a) The following activities would be regarded as "alterations" and would require registration and/or inspection by a licensed inspector:
 - (i) relocation of a tank;
 - (ii) upgrading of lines (vent, fill or product);
 - (iii) relocation of product lines [this includes all relocations of product lines other than that described in item 4(b)(iii)];
 - (iv) upgrading, relocation or addition of a valve;
 - (v) upgrading or replacement of secondary containment; or
 - (vi) addition of a filter assembly.
 - b) The following activities would not be regarded as "alterations" and would not require registration:
 - (i) removal of a heating oil storage tank system;
 - (ii) replacement of vent, fill or product lines (same size, length, diameter and material);
 - (iii) replacement of under, or in, floor product lines with above floor product lines.
 - (iv) replacement of a valve;
 - (v) replacement of a filter assembly or parts thereof;
 - (vi) replacement of a gauge or vent alarm;
 - (vii) addition of a gauge protector or tank valve protector;
 - (viii) replacement of tank legs with new same size tank legs; or

- (ix) any disconnection and reconnection of product lines to the burner assembly for the purpose of burner assembly repair or maintenance.

ANNEX F
MAKING AN “OUTSIDE” TANK
REGISTERABLE AS AN “INSIDE” TANK

Some people would like to have an inside tank rather than an outside tank but do not have a suitable location or space in their home to put a tank inside. Such people have inquired as to what would be necessary to convert their tank which is located outside to a tank which would be considered inside. In other words, how would an outside tank have to be reconfigured so that it could legitimately be registered as an inside tank.

For an outside tank system to be considered inside the arrangement would have to be reconfigured so as meet the following criteria:

- a) it shall be completely enclosed and protected from the elements with walls and roof being of solid and weather tight construction. This will eliminate the exposure of the outer surface of the tank to external weathering elements (i.e. precipitation). This should also reduce the variability in the temperature of the tank and its contained heating oil on a daily basis - reducing condensation on the inner surface of the tank - which in turn should reduce internal corrosion.
- b) the enclosure may share one or more walls with a nearby structure.
- c) being completely enclosed from the elements shall eliminate the exposure to snow and ice loads - reducing the likelihood of the nipple, shut-off valve or product line breaking.
- d) the area surrounding the tank shall not be damp and be well ventilated.
- e) the area in which the tank is located shall be accessible to an inspector and the door to the area shall be solid, weather tight and not allow the ingress of precipitation.
- f) the tank shall be supported by a solid concrete pad or reinforced concrete blocks. If reinforced concrete blocks are used and the floor is earthen it shall be kept vegetation free at all times.
- g) the tank’s vent shall terminate to the outside and be at least 600 mm (2 ft) from a door or operable window.
- h) the tank’s fill pipe shall be piped to the outside, shall be filled from the outside and be at least 600 mm (2 ft) from a door or operable window.
- i) be located such that there is a minimum clearance of 460 mm (18 in) from one side and the product supply valve end of the tank and a minimum of 50 mm (2 in) from the remaining side and end of the tank to the walls of the enclosure to allow access for inspection of the tank including the tank’s bottom.
- j) all other applicable requirements for an inside tank, although not mentioned here, must also be met.

In situations where someone has attempted to turn their outside tank into an inside one by enclosing the tank it may be difficult to determine whether the tank should be considered an inside one. The inspector should use the guidance provided in this Annex and their own best judgement. If necessary the department can be contacted for clarification.

Notes:

- Product lines may have to be located outside for a short distance to reach the home as the tank may be located in a nearby detached shed or enclosure.
- Some tanks are installed on reinforced patio blocks in earthen floored basements and these have been registered as inside tanks.
- Some tanks are located in unheated sheds and garages (both attached and detached from the adjacent house) and these have been registered as inside tanks.

ANNEX G

TAGS DECLARED VOID

A HOST tag may be declared “void” by a Licensed Inspector or by the Administrator. If a tag has been declared “void” then any tank to which it is attached would be considered unregistered. Such a tank must be removed from service if its useable lifetime has expired or must be inspected and registered if there is useable lifetime remaining for it. The usual circumstance under which a HOST tag would be declared “void” is that no registration information concerning a system to which the tag is or was supposed to be attached has ever been submitted to the Department. A declaration of “void” is permanent.

In such situations, where the tank has been tagged, the Department will allow the registration of the heating oil tank system based on the requirements at the time the heating oil tank was installed. The most significant aspect of this allowance is that the registration of single walled steel tanks located outside would be permitted. This is, however, based on the following conditions.

- a) The Department must be contacted to determine whether the information on the heating oil tank system was submitted and whether the original inspector is currently active. A request to replace the voided HOST tag shall be made to the Department and shall be accompanied by clear digital pictures showing the voided tag riveted to the vent pipe, the tank’s ULC label and the entire tank including the product piping outlet.
- b) Inspection shall be based on the requirements at the time the tank was installed or if installation date is not known the date the tank was manufactured. That said, although the tank may have been installed/manufactured prior to 2002 the earliest edition of the CSA B139 code which can be followed would be the 2000 edition. Also the earliest version of the System Installation and Inspection Manual which can be followed would be April 16, 2002.
- c) The existing tag must be removed and sent to the Department.
- d) The existing tag must be replaced with a new tag issued to an inspector.
- e) The new tag must be stamped based on the date the tank was installed not on what had been previously stamped on the existing tag (as this may be incorrect or not even present). If the installation date cannot be confirmed then the Licensed Inspector shall follow the requirements in paragraph 5.1. Remember that if the installation month is not known and the month of manufacture is not stamped on the ULC label, then the month of June (“06”) must be stamped on the HOST tag.
- f) A new Certificate of Registration shall be provided to the tank owner and date of issue noted shall be the date the new Certificate is issued.
- g) The new inspection checklist must show the date the new inspection was completed.

h) The electronic information must be submitted within a few days of the inspection and include the note (under the column “Notes”) “Replaces tag #0XXXXX”. Clear digital pictures showing the new tag riveted to the vent pipe, the tank’s ULC label and the entire tank including the product piping outlet shall be submitted with the electronic information for the tank to be considered registered.

ANNEX H

STORAGE TANK SYTEM RELOCATION

When a storage tank system is being relocated from an inside to an outside location or from an outside to an inside location it must be handled in a safe manner. All possible heating oil must be drained from the tank prior to it being moved. The tank system will have to be registered after being moved to its new location. This is the case whether or not the tank system was previously registered in its original location as several different requirements may now apply due to the change in location.

In the case of an inside tank system being relocated to an outside location you must take into account the difference in useable lifetimes assigned to a tank system dependent upon its location. For example, consider a tank system that has a useable lifetime of 20 years when located inside and a useable lifetime of 15 years when located outside. When relocated outside, the percentage of its original useable lifetime that has already been used while inside must be taken into account. So if the tank system had been used inside for 8 years and 7 months then that would be 43% of its original useable lifetime. Therefore, it would have 11 years and 5 months or 57% of its useable lifetime remaining in its present inside location. However, since it is being moved outside it will have a remaining lifetime based upon what the same tank system would have if it had been located outside all its life. In this case it would have a remaining lifetime of 57% of 15 years which would be about 8 years and 7 months.

In the case of an outside tank system being relocated to an inside location you must again take into account the difference in useable lifetimes assigned to a tank system dependent upon its location. For example, consider a tank system that has a useable lifetime of 15 years when located outside and a useable lifetime of 20 years when located inside. When relocated inside, the percentage of its original useable lifetime that has already been used while outside must be taken into account. So if the tank system had been used outside for 8 years and 7 months then that would be about 57% of its useable lifetime. Therefore, it would have 6 years and 5 months or about 43% of its useable lifetime remaining in its present outside location. However, since it is being moved inside it will have a remaining lifetime based upon what the same tank system would have if it had been located inside all its life. In this case it would have a remaining lifetime of 43% of 20 years which would be about 8 years and 7 months.

A Table of Remaining Useable Lifetimes for Relocated Tanks has been provided to assist in determining remaining useable lifetimes for relocated tanks. Note that the Table shows numbers for tanks used for full years (See last column). Where a tank is used for less than a full year, the calculation shall be as shown in the examples above and as shown in the Sample Calculations for Relocated Tanks Table. Rounding off of the “months in use or remaining” will likely be required however rounding off of the “years in use or remaining” shall not be permitted.

While moving a tank system from an outside location to an inside one, or the other way around, might seem worthwhile a person should consider the extra cost involved in doing such a thing.

Note that an inside single wall steel tank cannot be relocated outside.

Table of Remaining Useable Lifetimes for Relocated Tanks							
Useable Life Of Tank in Current Location	Outside Tank Going Inside			Inside Tank Going Outside *			Years of Use In Current Location
	10	15	20	20	25	30	
Useable Lifetime For New Location (years:months)	13y:6m	18y:8m	23y:9m	14y:3m	19y:2m	24y:2m	1
	12y:0m	17y:4m	22y:6m	13y:6m	18y:5m	23y:4m	2
	10y:6m	16y:0m	21y:3m	12y:9m	17y:7m	22y:6m	3
	9y:0m	14y:8m	20y:0m	12y:0m	16y:10m	21y:8m	4
	7y:6m	13y:4m	18y:9m	11y:3m	16y:0m	20y:10m	5
	6y:0m	12y:0m	17y:6m	10y:6m	15y:2m	20y:0m	6
	4y:6m	10y:8m	16y:3m	9y:9m	14y:5m	19y:2m	7
	3y:0m	9y:4m	15y:0m	9y:0m	13y:7m	18y:4m	8
	1y:6m	8y:0m	13y:9m	8y:3m	12y:10m	17y:6m	9
	0y:0m	6y:8m	12y:6m	7y:6m	12y:0m	16y:8m	10
	0y:0m	5y:4m	11y:3m	6y:9m	11y:2m	15y:10m	11
	0y:0m	4y:0m	10y:0m	6y:0m	10y:5m	15y:0m	12
	0y:0m	2y:8m	8y:9m	5y:3m	9y:7m	14y:2m	13
	0y:0m	1y:4m	7y:6m	4y:6m	8y:10m	13y:4m	14
	0y:0m	0y:0m	6y:3m	3y:9m	8y:0m	12y:6m	15
	0y:0m	0y:0m	5y:0m	3y:0m	7y:2m	11y:8m	16
	0y:0m	0y:0m	3y:9m	2y:3m	6y:5m	10y:10m	17
	0y:0m	0y:0m	2y:6m	1y:6m	5y:7m	10y:0m	18
	0y:0m	0y:0m	1y:3m	0y:9m	4y:10m	9y:2m	19
	0y:0m	0y:0m	0y:0m	0y:0m	4y:0m	8y:4m	20
	0y:0m	0y:0m	0y:0m	0y:0m	3y:2m	7y:6m	21
	0y:0m	0y:0m	0y:0m	0y:0m	2y:5m	6y:8m	22
	0y:0m	0y:0m	0y:0m	0y:0m	1y:7m	5y:10m	23
	0y:0m	0y:0m	0y:0m	0y:0m	0y:10m	5y:0m	24
	0y:0m	0y:0m	0y:0m	0y:0m	0y:0m	4y:2m	25
	0y:0m	0y:0m	0y:0m	0y:0m	0y:0m	3y:4m	26
	0y:0m	0y:0m	0y:0m	0y:0m	0y:0m	2y:6m	27
	0y:0m	0y:0m	0y:0m	0y:0m	0y:0m	1y:8m	28
	0y:0m	0y:0m	0y:0m	0y:0m	0y:0m	0y:10m	29
	0y:0m	0y:0m	0y:0m	0y:0m	0y:0m	0y:0m	30

The Table is based upon the following formulas:

(Time in use/useable lifetime) X 100 = percentage of life used = L1

Percentage of life remaining = 100 - L1 = L2

Time that tank can be used in other location = (useable lifetime in other location) X L2

See worked examples in table on next page.

* Note that a single wall steel tank located inside cannot be relocated outside.

Sample Calculations for Relocated Tanks

Example #1:

Consider a 12 gauge bottom outlet tank located outside (has been assigned a life of 20 yrs or 240 months) which has been in use for 8 years, 5 months and 7 days (or rounded down to 101 months) and is now being relocated inside.

$$\% \text{ life used} = L1 = 101/240 \times 100 = 42\%$$

$$\% \text{ life remaining} = L2 = 100\% - L1 = 100\% - 42\% = 58\%$$

Number of months remaining when relocated to an inside location

$$= 300 \times L2 = 300 \times 58\% = 174 \text{ months or 14 years and 6 months.}$$

[12 gauge bottom outlet tank located inside has been assigned a life of 25 yrs or 300 months]

Example #2

Consider a 14 gauge end outlet double bottom (including heads) steel tank located inside (has been assigned a life of 25 yrs or 300 months) which has been in use for 7 years, 11 months and 23 days (or rounded up to 96 months) and is now being relocated outside.

$$\% \text{ life used} = L1 = 96/300 \times 100 = 32\%$$

$$\% \text{ life remaining} = L2 = 100\% - L1 = 100\% - 32\% = 68\%$$

Number of months remaining when relocated to an outside location

$$= 240 \times L2 = 240 \times 68\% = 163 \text{ months or 13 years and 7 months.}$$

[14 gauge end outlet double bottom (including heads) steel tank located outside has been assigned a life of 20 yrs or 240 months]

Note: Where a tank has been used for, as an example, 8 years and 7 months, the calculations shown in this Annex shall be conducted using the actual number of months. Rounding off the years in use shall not be done.

Example #2 would not be permitted if the steel tank was single walled as such relocations require re-registration and single walled steel tanks will not be registerable outside.

A single walled steel tank located outside could not be moved to another location outside as such relocations require re-registration and single walled steel tanks are not registerable outside.